



Installation and Operation Instructions ED3801 and ED3802 Directional LED

IMPORTANT! Read all instructions before installing and using. Installer: This manual must be delivered to the end user.

WARNING!
 Failure to install or use this product according to manufacturer's recommendations may result in property damage, serious injury, and/or death to those you are seeking to protect!

 **Do not install and/or operate this safety product unless you have read and understood the safety information contained in this manual.**

1. Proper installation combined with operator training in the use, care, and maintenance of emergency warning devices are essential to ensure the safety of emergency personnel and the public.
2. Emergency warning devices often require high electrical voltages and/or currents. Exercise caution when working with live electrical connections.
3. This product must be properly grounded. Inadequate grounding and/or shorting of electrical connections can cause high current arcing, which can cause personal injury and/or severe vehicle damage, including fire.
4. Proper placement and installation is vital to the performance of this warning device. Install this product so that output performance of the system is maximized and the controls are placed within convenient reach of the operator so that they can operate the system without losing eye contact with the roadway.
5. Do not install this product or route any wires in the deployment area of an air bag. Equipment mounted or located in an air bag deployment area may reduce the effectiveness of the air bag or become a projectile that could cause serious personal injury or death. Refer to the vehicle owner's manual for the air bag deployment area. It is the responsibility of the user/operator to determine a suitable mounting location ensuring the safety of all passengers inside the vehicle particularly avoiding areas of potential head impact.
6. It is the responsibility of the vehicle operator to ensure daily that all features of this product work correctly. In use, the vehicle operator should ensure the projection of the warning signal is not blocked by vehicle components (i.e., open trunks or compartment doors), people, vehicles or other obstructions.
7. The use of this or any other warning device does not ensure all drivers can or will observe or react to an emergency warning signal. Never take the right-of-way for granted. It is the vehicle operator's responsibility to be sure they can proceed safely before entering an intersection, drive against traffic, respond at a high rate of speed, or walk on or around traffic lanes.
8. This equipment is intended for use by authorized personnel only. The user is responsible for understanding and obeying all laws regarding emergency warning devices. Therefore, the user should check all applicable city, state, and federal laws and regulations. The manufacturer assumes no liability for any loss resulting from the use of this warning device.

Specifications:

Input Voltage:		12 - 24VDC
Work Current:	ED3801X	0.8A @ 12VDC
	ED3802XX	0.8A @ 12VDC
	ED3802XXX	0.9A @ 12VDC
Temp. Range:		-40°C to 65°C -40°F to 149°F

Installation and Mounting:

IMPORTANT! This unit is a safety device and it must be connected to its own separate, fused power point to assure its continued operation should any other electrical accessory fail.



CAUTION! When drilling into any vehicle surface, make sure that the area is free from any electrical wires, fuel lines, vehicle upholstery, etc. that could be damaged.

Note: It is recommended to isolate wires/blunt wires that were cut or not used.

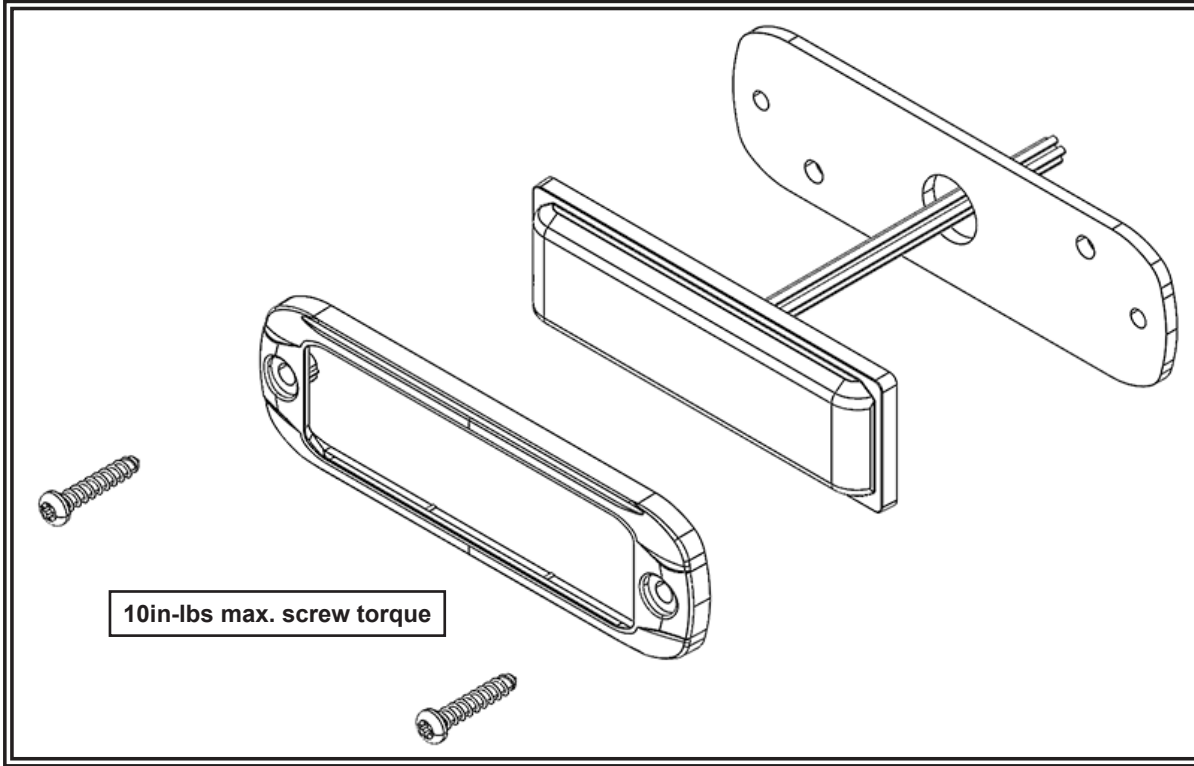

Figure 1

Wiring Instructions:

ED3801X

RED Wire: Positive (need to add 2A fuse)
BLACK Wire: Negative
BLUE Wire: Pattern Select to Negative
YELLOW Wire: Synchronized Function
(Up to 8 units can be Synchronized)

ED3802XX

RED Wire: Positive, Colors 1 & 3 (need to add 2A fuse)
WHITE Wire: Positive, Colors 2 & 4 (need to add 2A fuse)
BLACK Wire: Negative
BLUE Wire: Pattern Select to Negative
YELLOW Wire: Synchronized Function
(Up to 8 units can be Synchronized)

ED3802XXX

RED Wire: Positive, Group 1 (need to add 2A fuse)
WHITE Wire: Positive, Group 2 (need to add 2A fuse)
RED & WHITE Wire: Positive, Group 3 (need to add 2A fuse)
BLACK Wire: Negative
BLUE Wire: Pattern Select to Negative
YELLOW Wire: Synchronized Function
GREEN Wire: Mode Select
(Up to 8 units can be Synchronized)

Flash Patterns:

Phase Operation:

- Phase 1 (Ph1) flashes simultaneously with Ph1
- Phase 2 (Ph2) flashes simultaneously with Ph2
- Ph1 alternates with Ph2
- (Up to 8 units can be Synchronized)

Apply BLUE TO BLACK wire:

- Less than 1 sec. for next pattern
- Between 1-3 sec for previous pattern
- Between 3-5 sec. for factory default pattern
- More than 5 sec. for pattern 12 (ED3802XX, ED3802XXX) and pattern 13 (ED3801X)

SINGLE COLOR FLASH PATTERN CHART

Pattern	MODE	PATTERNS	Mark	SYNC.	SAE J595				CA T13			ECE R65		
					RED	AMBER	BLUE	WHITE	RED	AMBER	BLUE	RED	AMBER	BLUE
1	1	Single Flash 75FPM sim. Phase1	A	yes	Class 1	Class 1	Class 1	Class 1	Class B	Class B	Class B	N/C	N/C	N/C
	2	Single Flash 75FPM sim. Phase2		yes	Class 1	Class 1	Class 1	Class 1	Class B	Class B	Class B	N/C	N/C	N/C
	3	Single Flash 75FPM Alt.		yes	N/C	N/C	N/C	N/C	N/C	N/C	N/C	N/C	N/C	N/C
2	4	Single Flash 120FPM sim. Phase1	B	yes	Class 1	Class 1	Class 1	Class 1	N/C	N/C	N/C	N/C	N/C	N/C
	5	Single Flash 120FPM sim. phase2		yes	Class 1	Class 1	Class 1	Class 1	N/C	N/C	N/C	N/C	N/C	N/C
	6	Single Flash 120FPM Alt.		yes	N/C	N/C	N/C	N/C	N/C	N/C	N/C	N/C	N/C	N/C
3	7	Double Flash 75FPM sim. Phase1	A	yes	Class 1	Class 1	Class 1	Class 1	Class B	Class B	Class B	N/C	N/C	N/C
	8	Double Flash 75FPM sim. phase2		yes	Class 1	Class 1	Class 1	Class 1	Class B	Class B	Class B	N/C	N/C	N/C
	9	Double Flash 75FPM Alt.		yes	N/C	N/C	N/C	N/C	N/C	N/C	N/C	N/C	N/C	N/C
4	10	Double Flash 120FPM sim. Phase1	B	yes	Class 1	Class 1	Class 1	Class 1	N/C	N/C	N/C	Class 1	Class 1	Class 1
	11	Double Flash 120FPM sim. phase2		yes	Class 1	Class 1	Class 1	Class 1	N/C	N/C	N/C	Class 1	Class 1	Class 1
	12	Double Flash 120FPM Alt.		yes	N/C	N/C	N/C	N/C	N/C	N/C	N/C	N/C	N/C	N/C
5	13-Default	Quad Flash 75FPM sim. Phase1	A	yes	Class 1	Class 1	Class 1	Class 1	N/C	N/C	N/C	N/C	N/C	N/C
	14	Quad Flash 75FPM sim. Phase2		yes	Class 1	Class 1	Class 1	Class 1	N/C	N/C	N/C	N/C	N/C	N/C
	15	Quad Flash 75FPM Alt.		yes	N/C	N/C	N/C	N/C	N/C	N/C	N/C	N/C	N/C	N/C
6	16	Quad Flash 150FPM sim. Phase1	C	yes	Class 1	Class 1	Class 1	Class 2	N/C	N/C	N/C	N/C	N/C	N/C
	17	Quad Flash 150FPM sim. Phase2		yes	Class 1	Class 1	Class 1	Class 2	N/C	N/C	N/C	N/C	N/C	N/C
	18	Quad Flash 150FPM Alt		yes	N/C	N/C	N/C	N/C	N/C	N/C	N/C	N/C	N/C	N/C
7	19	Triple 75FPM sim. Phase1	A	yes	Class 1	Class 1	Class 1	Class 1	N/C	N/C	N/C	N/C	N/C	N/C
	20	Triple 75FPM sim. Phase2		yes	Class 1	Class 1	Class 1	Class 1	N/C	N/C	N/C	N/C	N/C	N/C
	21	Triple 75FPM Alt.		yes	N/C	N/C	N/C	N/C	N/C	N/C	N/C	N/C	N/C	N/C
8	22	Quint Flash 150FPM sim. Phase1	C	yes	Class 1	Class 1	Class 1	Class 1	N/C	N/C	N/C	N/C	N/C	N/C
	23	Quint Flash 150FPM sim. Phase2		yes	Class 1	Class 1	Class 1	Class 1	N/C	N/C	N/C	N/C	N/C	N/C
	24	Quint Flash 150FPM Alt.		yes	N/C	N/C	N/C	N/C	N/C	N/C	N/C	N/C	N/C	N/C
9	25	Steady - Single	N/A	NO	N/C	N/C	N/C	N/C	N/C	N/C	N/C	N/C	N/C	N/C
10	26	Steady Burn		NO	N/C	N/C	N/C	N/C	N/C	N/C	N/C	N/C	N/C	N/C
11	27	Modulation		NO	N/C	N/C	N/C	N/C	N/C	N/C	N/C	N/C	N/C	N/C
12	28	2 Double Flash,2 Triple Alt.		NO	N/C	N/C	N/C	N/C	N/C	N/C	N/C	N/C	N/C	N/C
13	29	4 Single Flash ,2 Quad Flash Alt.		NO	N/C	N/C	N/C	N/C	N/C	N/C	N/C	N/C	N/C	N/C

DUAL COLOR FLASH PATTERN CHART

Pattern	LED Color 1 & Color 3 Red line	LED Color 2 & Color 4 White line	LED Color 1 & Color 3 LED Color 2 & Color 4 Red & White line	PATTERNS	Mark	SYNC.	SAE J595	CA T13	ECE R65	
							RED, AMBER, BLUE, WHITE	RED, AMBER, BLUE	RED, AMBER, BLUE	
1	1-Default		1	Single 75FPM Ph1 Color 1 Synchronous Color 3	A	yes	Class 1	Class B	N/C	
	2		2	Single 75FPM Ph2 Color 1 Synchronous Color 3		yes	Class 1	Class B	N/C	
			3	Single 75FPM Ph1 Color 1 Alternately Color 4		yes	N/C	N/C	N/C	
			4	Single 75FPM Ph2 Color 1 Alternately Color 4		yes	N/C	N/C	N/C	
		1-Default	5	Single 75FPM Ph1 Color 2 Synchronous Color 4		yes	Class 1	Class B	N/C	
		2	6	Single 75FPM Ph2 Color 2 Synchronous Color 4		yes	Class 1	Class B	N/C	
	3		7	Single 38FPM Ph1(Color 1 Synchronous Color 3) Alternately (Color 2 Synchronous Color 4)		yes	N/C	N/C	N/C	
	4		8	Single 38FPM Ph2(Color 1 Synchronous Color 3) Alternately (Color 2 Synchronous Color 4)		yes	N/C	N/C	N/C	
	5	5	9	Single 38FPM (Color 1 Alternately Color 2) Alternately (Color 3 Alternately Color 4)		yes	N/C	N/C	N/C	
			10	Single 375FPMFPM Ph1 Color 1 Synchronous Color 3		yes	N/C	N/C	N/C	
2			11	Single 375FPMFPM Ph2 Color 1 Synchronous Color 3	D	yes	N/C	N/C	N/C	
			12	Single 375FPMFPM Ph1 Color 1 Alternately Color 4		yes	N/C	N/C	N/C	
			13	Single 375FPMFPM Ph2 Color 1 Alternately Color 4		yes	N/C	N/C	N/C	
		6	14	Single 375FPMFPM Ph1 Color 2 Synchronous Color 4		yes	N/C	N/C	N/C	
		7	15	Single 375FPMFPM Ph2 Color 2 Synchronous Color 4		yes	N/C	N/C	N/C	
	8	8	16	Single 187FPMFPM Ph1 (Color 1 Synchronous Color 3) Alternately (Color 2 Synchronous Color 4)		yes	N/C	N/C	N/C	
	9	9	17	Single 187FPMFPM Ph2 (Color 1 Synchronous Color 3) Alternately (Color 2 Synchronous Color 4)		yes	N/C	N/C	N/C	
	10	10	18	Single 187FPMFPM (Color 1 Alternately Color 2) Alternately (Color 3 Alternately Color 4)		yes	N/C	N/C	N/C	
			19	Double 75FPM Ph1 Color 1 Synchronous Color 3		A	yes	Class 1	Class B	N/C
			20	Double 75FPM Ph2 Color 1 Synchronous Color 3			yes	Class 1	Class B	N/C
		21	Double 75FPM Ph1 Color 1 Alternately Color 4	yes	N/C		N/C	N/C		
		22	Double 75FPM Ph2 Color 1 Alternately Color 4	yes	N/C		N/C	N/C		
	11	23	Double 75FPM Ph1 Color 2 Synchronous Color 4	yes	Class 1		Class B	N/C		
	12	24	Double 75FPM Ph2 Color 2 Synchronous Color 4	yes	Class 1		Class B	N/C		
13	13	25	Double 38FPM Ph1 (Color 1 Synchronous Color 3) Alternately (Color 2 Synchronous Color 4)	yes	N/C		N/C	N/C		
14	14	26	Double 38FPM Ph2 (Color 1 Synchronous Color 3) Alternately (Color 2 Synchronous Color 4)	yes	N/C		N/C	N/C		
15	15	27	Double 38FPM (Color 1 Alternately Color 2) Alternately (Color 3 Alternately Color 4)	yes	N/C		N/C	N/C		
		28	Double 120FPM Ph1 Color 1 Synchronous Color 3	B	yes		Class 1	N/C	Class 1	
		29	Double 120FPM Ph2 Color 1 Synchronous Color 3		yes	Class 1	N/C	Class 1		
		30	Double 120FPM Ph1 Color 1 Alternately Color 4		yes	N/C	N/C	N/C		
		31	Double 120FPM Ph2 Color 1 Alternately Color 4		yes	N/C	N/C	N/C		
	16	32	Double 120FPM Ph1 Color 2 Synchronous Color 4		yes	Class 1	N/C	Class 1		
	17	33	Double 120FPM Ph2 Color 2 Synchronous Color 4		yes	Class 1	N/C	Class 1		
18	18	34	Double 60FPM Ph1 (Color 1 Synchronous Color 3) Alternately (Color 2 Synchronous Color 4)		yes	N/C	N/C	N/C		
19	19	35	Double 60FPM Ph2 (Color 1 Synchronous Color 3) Alternately (Color 2 Synchronous Color 4)		yes	N/C	N/C	N/C		
20	20	36	Double 60FPM (Color 1 Alternately Color 2) Alternately (Color 3 Alternately Color 4)		yes	N/C	N/C	N/C		
		37	Triple 75FPM Ph1 Color 1 Synchronous Color 3		A	yes	Class 1	N/C	N/C	
		38	Triple 75FPM Ph2 Color 1 Synchronous Color 3	yes		Class 1	N/C	N/C		
		39	Triple 75FPM Ph1 Color 1 Alternately Color 4	yes		N/C	N/C	N/C		
		40	Triple 75FPM Ph2 Color 1 Alternately Color 4	yes		N/C	N/C	N/C		
	21	41	Triple 75FPM Ph1 Color 2 Synchronous Color 4	yes		Class 1	N/C	N/C		
	22	42	Triple 75FPM Ph2 Color 2 Synchronous Color 4	yes		Class 1	N/C	N/C		
23	23	43	Triple 38FPM Ph1 (Color 1 Synchronous Color 3) Alternately (Color 2 Synchronous Color 4)	yes		N/C	N/C	N/C		
24	24	44	Triple 38FPM Ph2 (Color 1 Synchronous Color 3) Alternately (Color 2 Synchronous Color 4)	yes		N/C	N/C	N/C		
25	25	45	Triple 38FPM (Color 1 Alternately Color 2) Alternately (Color 3 Alternately Color 4)	yes		N/C	N/C	N/C		
		46	Quad 75FPM Ph1 Color 1 Synchronous Color 3	A		yes	Class 1	N/C	N/C	
		47	Quad 75FPM Ph2 Color 1 Synchronous Color 3		yes	Class 1	N/C	N/C		
		48	Quad 75FPM Ph1 Color 1 Alternately Color 4		yes	N/C	N/C	N/C		
		49	Quad 75FPM Ph2 Color 1 Alternately Color 4		yes	N/C	N/C	N/C		
	26	50	Quad 75FPM Ph1 Color 2 Synchronous Color 4		yes	Class 1	N/C	N/C		
	27	51	Quad 75FPM Ph2 Color 2 Synchronous Color 4		yes	Class 1	N/C	N/C		
28	28	52-Default	Quad 38FPM Ph1 (Color 1 Synchronous Color 3) Alternately (Color 2 Synchronous Color 4)		yes	N/C	N/C	N/C		
29	29	53	Quad 38FPM Ph2 (Color 1 Synchronous Color 3) Alternately (Color 2 Synchronous Color 4)		yes	N/C	N/C	N/C		
30	30	54	Quad 38FPM (Color 1 Alternately Color 2) Alternately (Color 3 Alternately Color 4)		yes	N/C	N/C	N/C		
		55	Quad 120FPM Ph1 Color 1 Synchronous Color 3		B	yes	Class 1	N/C	N/C	
		56	Quad 120FPM Ph2 Color 1 Synchronous Color 3	yes		Class 1	N/C	N/C		
		57	Quad 60FPM Ph1 Color 1 Alternately Color 4	yes		N/C	N/C	N/C		
		58	Quad 120FPM Ph2 Color 1 Alternately Color 4	yes		N/C	N/C	N/C		
	31	59	Quad 120FPM Ph1 Color 2 Synchronous Color 4	yes		Class 1	N/C	N/C		
	32	60	Quad 120FPM Ph2 Color 2 Synchronous Color 4	yes		Class 1	N/C	N/C		
33	33	61	Quad 60FPM Ph1 (Color 1 Synchronous Color 3) Alternately (Color 2 Synchronous Color 4)	yes		N/C	N/C	N/C		
34	34	62	Quad 60FPM Ph2 (Color 1 Synchronous Color 3) Alternately (Color 2 Synchronous Color 4)	yes		N/C	N/C	N/C		
35	35	63	Quad 60FPM (Color 1 Alternately Color 2) Alternately (Color 3 Alternately Color 4)	yes		N/C	N/C	N/C		
		64	Modulation (Color 1 Synchronous Color 3) Alternately (Color 2 Synchronous Color 4)	N/A		no	N/C	N/C	N/C	
8		65	2 Double,2 Quad (Color 1 Synchronous Color 3) Alternately (Color 2 Synchronous Color 4)		no	N/C	N/C	N/C		
10		66	4 Single,2 Triple (Color 1 Synchronous Color 3) Alternately (Color 2 Synchronous Color 4)		no	N/C	N/C	N/C		
11		67	1Double 1Triple 1Quad (Color 1 Synchronous Color 3) Alternately (Color 2 Synchronous Color 4)		no	N/C	N/C	N/C		
	36	68	Steady burn-Color 1 & 3		no	N/C	N/C	N/C		
12		69	Steady burn-Color 2 & 4		no	N/C	N/C	N/C		

9	17							17							CA T13 Single Flash 75FPM Color 1	N/A	no	class 1	class B	N/C
		17							17						CA T13 Single Flash 75FPM Color 2		no	class 1	class B	N/C
			17								17				CA T13 Single Flash 75FPM Color 3		no	class 1	class B	class B
10	18							18							CA T13 Double Flash 75FPM Color 1		no	class 1	class B	N/C
		18							18						CA T13 Double Flash 75FPM Color 2		no	class 1	class B	N/C
			18							18					CA T13 Double Flash 75FPM Color 3		no	class 1	class B	class B
11	19							19							NFPA-Quad Flash 75FPM Color 1		no	class 1	class B	N/C
		19							19						NFPA-Quad Flash 75FPM Color 2		no	class 1	class B	N/C
			19								19				NFPA-Quad Flash 75FPM Color 3		no	class 1	class B	class B
12	20							20							ModuFlash sim. Color 1		no	N/C	N/C	N/C
		20							20						ModuFlash sim. Color 2		no	N/C	N/C	N/C
			20							20					ModuFlash sim. Color 3		no	N/C	N/C	N/C
13	21							21							2 Double Flash,2 Quad Flash Color 1		no	N/C	N/C	N/C
		21							21						2 Double Flash,2 Quad Flash Color 2		no	N/C	N/C	N/C
			21								21				2 Double Flash,2 Quad Flash Color 3		no	N/C	N/C	N/C
14	22							22							4 Single Flash,2 Triple Flash Color 1		no	N/C	N/C	N/C
		22							22						4 Single Flash,2 Triple Flash Color 2		no	N/C	N/C	N/C
			22							22					4 Single Flash,2 Triple Flash Color 3		no	N/C	N/C	N/C
15	23							23							Autorun Color 1	no	N/C	N/C	N/C	
		23							23						Autorun Color 2	no	N/C	N/C	N/C	
			23							23					Autorun Color 3	no	N/C	N/C	N/C	
16	24							24							steady burn Color 1	no	N/C	N/C	N/C	
		24							24						steady burn Color 2	no	N/C	N/C	N/C	
			24							24					steady burn Color 3	no	N/C	N/C	N/C	

Troubleshooting:

The ED3801X, ED3802XX, and ED3802XXX series are factory tested and approved. If any of the functions of the device fail to operate, please check the following:

PROBLEM	QUESTION	CAUSE	SOLUTION	
Product does not function when turned on	Are LEDs functioning properly?	Yes	a. Plug is loose or disconnected. b. Poor ground connection	a. Reconnect plug. b. Reconnect ground.
		No	a. Power has been disconnected.	a. Check connections at the battery and plug.

Warranty:

Manufacturer Limited Warranty Policy:

Manufacturer warrants that on the date of purchase this product will conform to Manufacturer's specifications for this product (which are available from the Manufacturer upon request). This Limited Warranty extends for Sixty (60) months from the date of purchase.

DAMAGE TO PARTS OR PRODUCTS RESULTING FROM TAMPERING, ACCIDENT, ABUSE, MISUSE, NEGLIGENCE, UNAPPROVED MODIFICATIONS, FIRE OR OTHER HAZARD; IMPROPER INSTALLATION OR OPERATION; OR NOT BEING MAINTAINED IN ACCORDANCE WITH THE MAINTENANCE PROCEDURES SET FORTH IN MANUFACTURER'S INSTALLATION AND OPERATING INSTRUCTIONS VOIDS THIS LIMITED WARRANTY.

Exclusion of Other Warranties:

MANUFACTURER MAKES NO OTHER WARRANTIES, EXPRESS OR IMPLIED. THE IMPLIED WARRANTIES FOR MERCHANTABILITY, QUALITY OR FITNESS FOR A PARTICULAR PURPOSE, OR ARISING FROM A COURSE OF DEALING, USAGE OR TRADE PRACTICE ARE HEREBY EXCLUDED AND SHALL NOT APPLY TO THE PRODUCT AND ARE HEREBY DISCLAIMED, EXCEPT TO THE EXTENT PROHIBITED BY APPLICABLE LAW. ORAL STATEMENTS OR REPRESENTATIONS ABOUT THE PRODUCT DO NOT CONSTITUTE WARRANTIES.

Remedies and Limitation of Liability:

MANUFACTURER'S SOLE LIABILITY AND BUYER'S EXCLUSIVE REMEDY IN CONTRACT, TORT (INCLUDING NEGLIGENCE), OR UNDER ANY OTHER THEORY AGAINST MANUFACTURER REGARDING THE PRODUCT AND ITS USE SHALL BE, AT MANUFACTURER'S DISCRETION, THE REPLACEMENT OR REPAIR OF THE PRODUCT, OR THE REFUND OF THE PURCHASE PRICE PAID BY BUYER FOR NON-CONFORMING PRODUCT. IN NO EVENT SHALL MANUFACTURER'S LIABILITY ARISING OUT OF THIS LIMITED WARRANTY OR ANY OTHER CLAIM RELATED TO THE MANUFACTURER'S PRODUCTS EXCEED THE AMOUNT PAID FOR THE PRODUCT BY BUYER AT THE TIME OF THE ORIGINAL PURCHASE. IN NO EVENT SHALL MANUFACTURER BE LIABLE FOR LOST PROFITS, THE COST OF SUBSTITUTE EQUIPMENT OR LABOR, PROPERTY DAMAGE, OR OTHER SPECIAL, CONSEQUENTIAL, OR INCIDENTAL DAMAGES BASED UPON ANY CLAIM FOR BREACH OF CONTRACT, IMPROPER INSTALLATION, NEGLIGENCE, OR OTHER CLAIM, EVEN IF MANUFACTURER OR A MANUFACTURER'S REPRESENTATIVE HAS BEEN ADVISED OF THE POSSIBILITY OF SUCH DAMAGES. MANUFACTURER SHALL HAVE NO FURTHER OBLIGATION OR LIABILITY WITH RESPECT TO THE PRODUCT OR ITS SALE, OPERATION AND USE, AND MANUFACTURER NEITHER ASSUMES NOR AUTHORIZES THE ASSUMPTION OF ANY OTHER OBLIGATION OR LIABILITY IN CONNECTION WITH SUCH PRODUCT.

This Limited Warranty defines specific legal rights. You may have other legal rights which vary from jurisdiction to jurisdiction. Some jurisdictions do not allow the exclusion or limitation of incidental or consequential damages.



833 West Diamond St, Boise, Idaho 83705
Customer Service USA 800-635-5900
UK +44 (0)113 237 5340 | AUS +61 (0)3 63322444
ECCOESG.com

An ECCO SAFETY GROUP™ Brand
ECCOSAFETYGROUP.com